



EIRP305-T

User Manual



EIRP305-T

Documentation Number: EIRP305-T- 0109m



International Headquarters

B&B Electronics Mfg. Co. Inc.

707 Dayton Road

Ottawa, IL 61350 USA

Phone (815) 433-5100 -- **General Fax** (815) 433-5105

Website: www.bb-elec.com

European Headquarters

B&B Electronics Ltd.

Westlink Commercial Park

Oranmore, Co. Galway, Ireland

Phone +353 91-792444 -- **Fax** +353 91-792445

Website: www.bb-europe.com

©2008 B & B Electronics Mfg. Co. Inc. No part of this publication may be reproduced or transmitted in any form or by any means, electronic or mechanical, including photography, recording, or any information storage and retrieval system without written consent. Information in this manual is subject to change without notice, and does not represent a commitment on the part of B&B Electronics Mfg. Co. Inc.

B&B Electronics Mfg. Co. Inc. shall not be liable for incidental or consequential damages resulting from the furnishing, performance, or use of this manual.

All Brand names used in this manual are the registered trademarks of their respective owners. The use of trademarks or other designations in this publication is for reference purposes only and does not constitute an endorsement by the trademark holder

Content

1. Introduction.....	1
<i>Features.....</i>	<i>1</i>
<i>Package Contents.....</i>	<i>1</i>
2. Hardware Description	2
<i>Physical Dimension.....</i>	<i>2</i>
<i>Front Panel</i>	<i>2</i>
<i>Top View.....</i>	<i>2</i>
<i>LED Indicators.....</i>	<i>3</i>
<i>Ports</i>	<i>3</i>
<i>Cabling.....</i>	<i>5</i>
<i>Wiring the Power Inputs</i>	<i>6</i>
<i>Wiring the Fault Alarm Contact.....</i>	<i>7</i>
3. Mounting Installation	8
<i>DIN-Rail Mounting</i>	<i>8</i>
<i>Wall Mount Plate Mounting.....</i>	<i>10</i>
4. Hardware Installation	11
<i>Installation Steps.....</i>	<i>11</i>
5. Network Application.....	12
6. Troubleshooting	13
7. Technical Specification.....	14

Introduction

The EIRP305-T is an industrial DIN mount, unmanaged 5 port Ethernet Switch with 4 PoE Injector ports. All ports support 10/100Mbps speeds.

Features

- System Interface/Performance
 - RJ-45 ports support Auto MDI/MDI-X Function
 - Embedded 4-port PoE Injection
 - Store-and-Forward Switching Architecture
 - Back-plane (Switching Fabric): 1.0Gbps
 - 2K MAC Address Table
- Power Supply
 - 48VDC Redundant Power
- Case/Installation
 - IP30 Protection
 - DIN Rail and Wall Mount Design
- Provides EFT protection 3,000 VDC for power line
- Supports 6,000 VDC Ethernet ESD protection

Package Contents

- (1) EIRP305-T, 5 Port Industrial Ethernet Switch with 4 PoE Ports
- (1) Quick Start Guide
- (1) CD ROM with User Manual
- (2) Wall Mounting Bracket and Screws

Hardware Description

Physical Dimension

(W x D x H) is 30mm x 95mm x 140mm (1.2 x 3.7 x 5.5 inches)

Front Panel

The Front Panel view of the EIRP305-T is shown below.



Top View

The top panel view of the EIRP305-T is equipped with one terminal block connector that consists of two 48 VDC power inputs and the fault alarm output.



Top View of the PoE Injectors Industrial Switch

LED Indicators

Below is a table that explains the status of each of the power and network status LED's found on the front panel of the EIRP305-T.

LED	Color	Description	
P1	Green	On	Power input 1 is active
		Off	Power input 1 is inactive
P2	Green	On	Power input 2 is active
		Off	Power input 2 is inactive
Fault	Red	On	Power input 1 or 2 has failed
		Off	Power input 1 and 2 are both functional, or no power is
FWD (1 to 4)	Green	On	The port is supplying power to the connected device
		Off	No device attached or no power being supplied
1 to 5 (RJ-45)	Green (Upper LED)	On	Connected to network
		Flashing	Networking is active
		Off	Not connected to network
	Yellow (Lower LED)	On	Full-duplex link
		Flashing	Collision occurs
		Off	Half-duplex link or link down

Ports

RJ-45 ports: The RJ-45 ports auto-sense for 10 or 100 Mbps device connections. The auto MDI/MDIX feature allows connections to switches, workstation and other equipment without changing straight through or crossover cabling. The charts below show the cable pin assignments for straight through and crossover cables.

■ RJ-45 Pin Assignments

Pin Number	Assignment
1	Tx+
2	Tx-
3	Rx+
6	Rx-

Note “+” and “-” signs represent the polarity of each wire pair.

All ports on the EIRP305-T support automatic MDI/MDI-X operation, you can use straight-through cables (See Figure below) for all network connections to PCs or servers, or to other switches or hubs. In straight-through cables, pins 1, 2, 3, and 6, at one end of the cable, are connected straight through to pins 1, 2, 3 and 6 at the other end of the cable. The table below shows the 10BASE-T / 100BASE-TX MDI and MDI-X port pin outs.

Pin	MDI-X Signal Name	MDI Signal Name
1	Receive Data plus (RD+)	Transmit Data plus (TD+)
2	Receive Data minus (RD-)	Transmit Data minus (TD-)
3	Transmit Data plus (TD+)	Receive Data plus (RD+)
6	Transmit Data minus (TD-)	Receive Data minus (RD-)

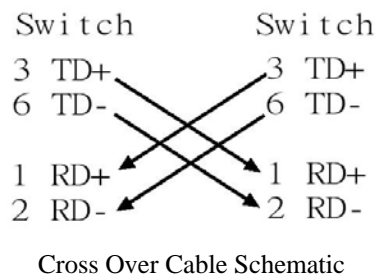
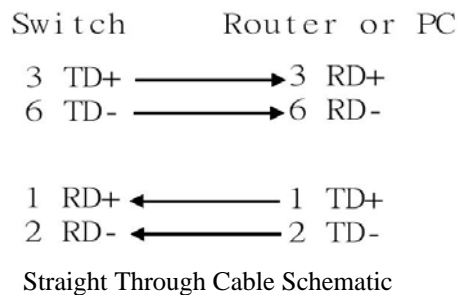

Cabling

Use unshielded twisted-pair (UTP) or shielded twisted-pair (STP) cable.

10Mbps: Use category 3, 4, 5 or greater cable

100Mbps: Use category 5 or greater

Cable distances should be less than 100 meters (328 ft.) long.

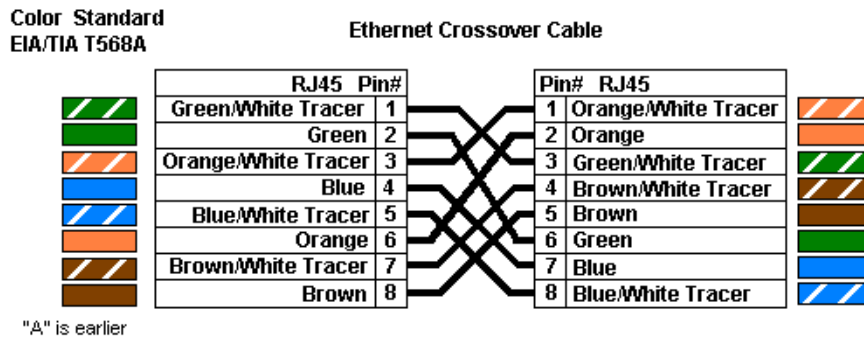
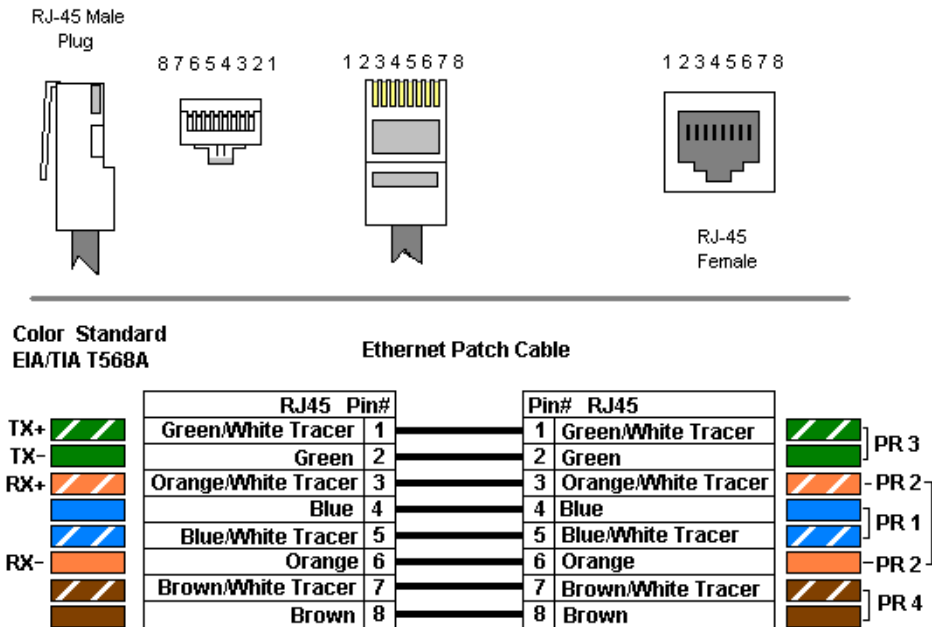

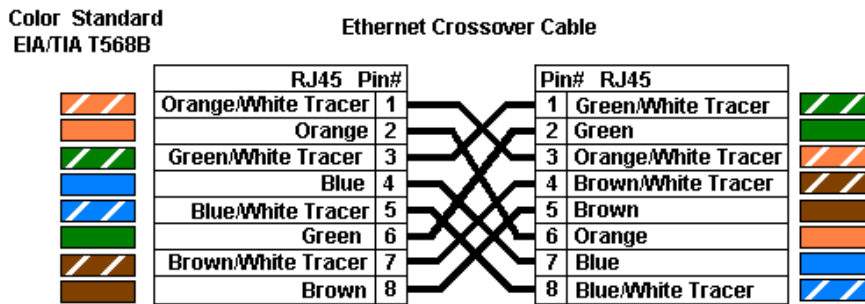
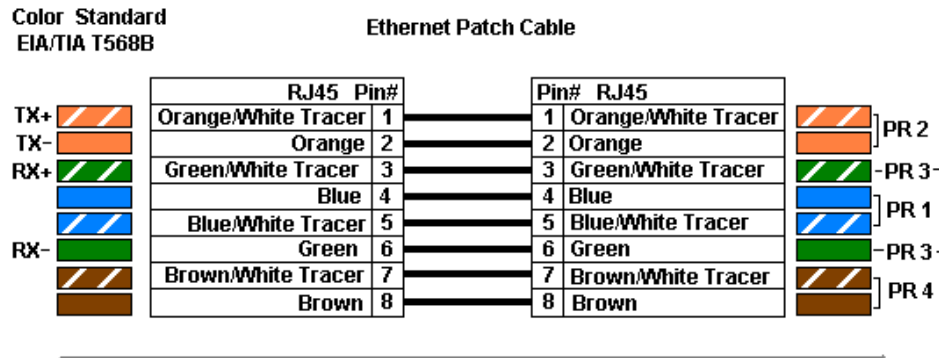

"B" is most recent

Common Ethernet Crossover Cables may only cross connect the Orange & Green pairs

Wiring the Power Inputs

Follow the steps below to insert the power wires.

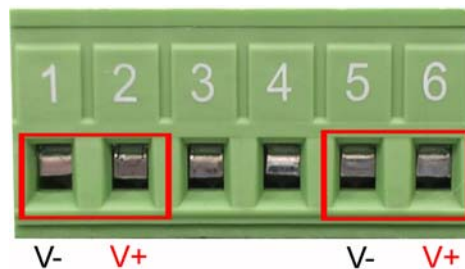

Insert the positive and negative wires into the V+ and V- contacts on the terminal block connector.



Tighten the wire-clamp screws to prevent the wires from becoming loose.

Wiring the Fault Alarm Contact

The fault alarm contact is in the middle of terminal block connector as the picture shows below. If one of the power sources fails a fault will be detected causing the circuit to open.



Insert the wires into the fault alarm contact.

Note *The wire gauge for the terminal block should be 12 to 24 AWG.*

Mounting Installation

DIN-Rail Mounting

The DIN rail clip comes screwed on to the switch, from the factory. If the DIN rail clip is not screwed on the switch, please see the following figure to re-attach the DIN-Rail clip. Then follow the steps below to hang the switch onto a DIN rail.

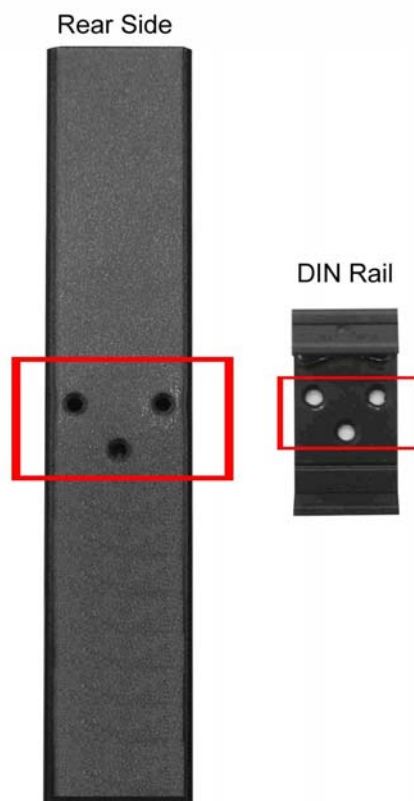

1. Use the screws to screw the DIN rail clip onto the switch.
2. To remove the DIN rail clip, reverse step 1.

3. First, insert the top of DIN rail clip onto the piece DIN rail track.



4. Then, lightly push the bottom of the switch so it can snap the rest of the way onto the DIN rail track.

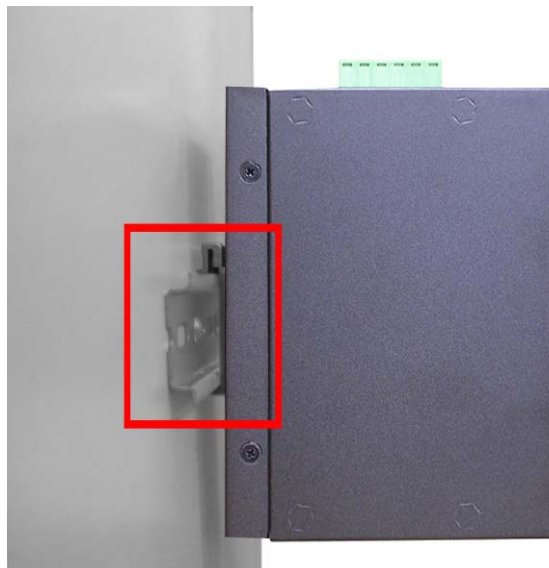

5. Check that the switch is held tightly to the DIN rail track.
6. To remove the switch from the track, reverse the steps above.
 - First pushing down lightly on the switch will give enough room for the bottom of the switch to clear the bottom of the DIN rail track.

- Pulling slowly at the bottom of the switch will bring the switch out so that the switch can now be carefully lifted off the DIN rail track.

Wall or Panel Mount Plate Mounting

Follow the steps below to mount the industrial switch with wall mount plate.

1. Remove the DIN rail clip from the switch; loosen the screws to remove the DIN rail clip.
2. Place the wall mount plate on the side panels of the switch.
3. Use the screws to screw the wall mount plate on the switch.
4. Use the hook holes at the corners of the wall mount plates to hang the switch on the wall.
5. To remove the wall mount plate, reverse steps above.

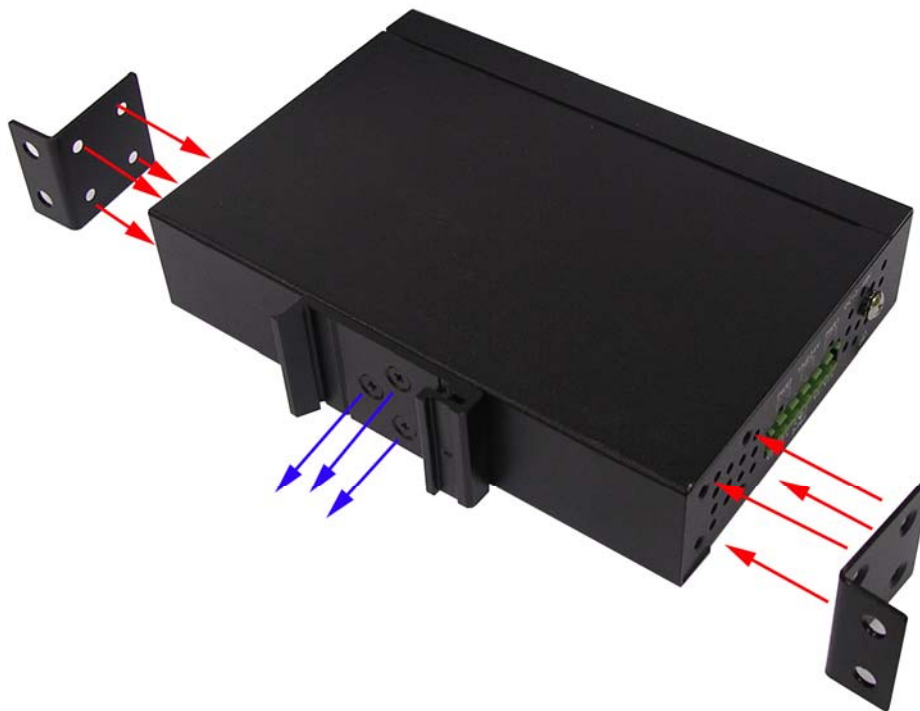

Hardware Installation

Installation Steps

1. Unpack the switch.
2. Check that the DIN rail is screwed onto the switch. If the DIN rail clip is not screwed onto the switch. Please refer to **DIN-Rail Mounting** section for DIN-Rail installation. If you want to wall or panel mount the switch, then please refer to **Wall or Panel Mount Plate Mounting**.
3. Apply power to the switch. If you need help with this please refer to the **Wiring the Power Inputs** section. The power LED on the switch will light up. Please refer to the **LED Indicators** section for meaning of LED lights.
4. Prepare the twisted-pair, Ethernet cable for connection.
5. Insert one side of cable into one of the switches Ethernet ports and the other side of the cable to the network device you want connected ex: switch, PC or Server. The port LED on the Industrial switch will light up when the cable is connected to the network device. Please refer to the **LED Indicators** section for LED light meaning.
6. When all connections are made and the LED lights show normal activity the installation is complete.

Network Application

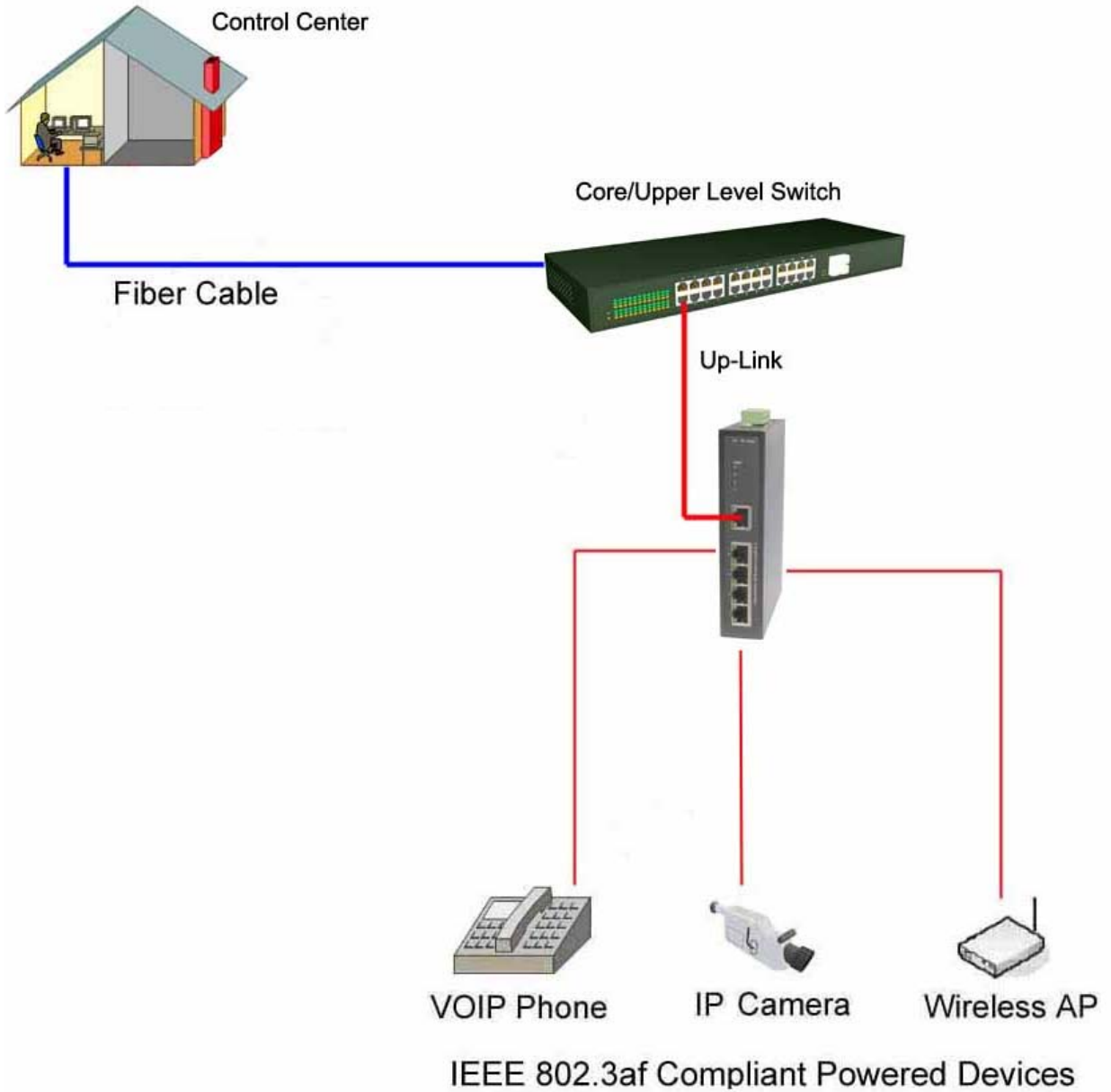

Troubleshooting

- Verify that you are using a 48VDC power supply. Applying more than 48VDC could cause damage to the switch.
- Be sure the proper cable is used in your network. Refer to the **Cabling** section of this manual for help.
- **Diagnosing LED Indicators:** The switch can be monitored through the LED indicators on the front panel of the switch. The LED's can help describes common problems you may encounter and where you may find possible solutions, to assist in identifying problems.
- If the power indicators do not light on when power is applied, you may have a problem with the power supply. Check for loose power connections, power losses or surges at the power outlet.
- If the switch LED's represent normal operating mode and the cable connections are correct and no data is transmitted or received through the switch, contact your Network Administrator for network configuration and status help.

Technical Specification

Standard	<p>IEEE 802.3 10Base-T Ethernet</p> <p>IEEE 802.3u 100Base-TX Fast Ethernet</p> <p>IEEE802.3x Flow Control and Back Pressure</p> <p>IEEE802.3af Power over Ethernet</p>
Protocol	CSMA/CD
Transfer Rate	<p>14,880 pps for 10Base-T Ethernet port</p> <p>148,800 pps for 100Base-TX Fast Ethernet port</p>
MAC Address	2K MAC address table
Connector	<p>10/100TX: 5 x RJ-45 with auto MDI/MDI-X function;</p> <p>Supports 4 PoE injector function</p>
PoE Pin Assignment	<p>RJ-45 port #1 ~ # 4 support IEEE 802.3af End-point, Alternative A mode.</p> <p>Positive (VCC+): RJ-45 pin 1, 2.</p> <p>Negative (VCC-): RJ-45 pin 3, 6.</p> <p>Data (1,2,3,6)</p>
LED	<p>Per unit: Power 1 (Green), Power 2 (Green), Fault(Red)</p> <p>Per port: Link/Activity (Green), Full duplex/Collision (Yellow)</p> <p>PoE: Feeding Power (Green)</p>

Network Cable	<p>10Base-T: 2-pair UTP/STP Cat. 3, 4, 5, 5e cable EIA/TIA-568 100-ohm (100m)</p> <p>100Base-TX: 2-pair UTP/STP Cat. 5/5e cable EIA/TIA-568 100-ohm (100m)</p>
Power Supply	Redundant 48VDC with removable terminal block
Power Consumption	3.4Watts (without PoE); 57 Watts (Full load with PoE)
Installation	DIN rail kit for DIN-type cabinet install and wall-mount ear for wall mounting
Operating Temp.	-40°C to 75°C
Operating Humidity	5% to 95% (Non-condensing)
Storage Temperature	-40°C to 85°C
Case Dimension	IP30, 30mm (W) x 95mm (D) x 140mm (H) (1.2 x 3.7 x 5.5 inches)
EMI	<p>FCC Class A</p> <p>CE EN61000-4-2/3/4/5/6/8/11/12</p> <p>CE EN61000-6-2</p> <p>CE EN61000-6-4</p>
Safety	<p>UL</p> <p>cUL</p> <p>CE/EN60950-1</p>

Stability testing	IEC60068-2-32 (Free fall) IEC60068-2-27 (Shock) IEC60068-2-6 (Vibration)
--------------------------	--