

POWER OVER ETHERNET (POE)

With the introduction of new Ethernet-enabled devices expanding geometrically, the need to power these devices from standard AC power outlets has become a limiting factor. IP telephones, wireless access points, IP cameras and device servers are examples of devices limited by the need to have an AC power outlet nearby to plug in a DC power adapter. At best, power supply installation and wiring adds labor and results in the mess of extra wiring; worst case, the lack of nearby AC power means devices cannot be installed where they are needed.

In response to this need, IEEE developed IEEE802.3af to standardize a system of supplying low voltage power to networked devices via the communications line. Released in mid-2003, the standard was entitled, *Data Terminal Equipment (DTE) Power via Media Dependant Interface (MDI)*. It is more commonly referred to as Power over Ethernet (POE). PoE supplies power to network devices over the same standard Category 5e (CAT-5) cabling that carries the data. Devices can be installed wherever structured Ethernet wiring is located, without the need for AC power outlets nearby.

The benefits of PoE include increased mobility for end devices, added safety (no AC power involved), simplicity of installation, reliability, security and cost savings. These advantages have led to the development of a variety of new PoE-enabled products (including B&B Electronics' PES1A and PESV1A RS-232 to Ethernet Converters).

How PoE Works

In the PoE scheme, two different types of devices are involved: **Power Sourcing Equipment (PSE)** and **Powered Devices (PD)**.

PDs are PoE-enabled network end devices equipped to accept low voltage power transmitted over structured Ethernet CAT-5 cabling.

PSEs provide the DC power to **PDs**. PSEs source up to 12 watts at 48 volts to each PD. A PSE may be an **endspan device** or a **midspan device**. An endspan device typically is a network switch enabled to provide PoE power on each port. A midspan device is connected in-line to each end device and adds power to the line.

Power is carried over the cabling using two techniques: **Alternative A** and **Alternative B**.

Alternative A implements a simplex, or 'phantom feeding' method for delivering power to the end device. Power is carried on the same conductors as data. CAT-5 cabling for standard 10BaseT and 100Base-TX Ethernet uses two data/signal pairs connected to pins 1 and 2 and pins 3 and 6 on RJ-45 connectors. Power sourcing equipment superimposes power onto these pins via the center tap of internal signal coupling transformers. In the powered device (PD) the power is derived from these lines using the reverse technique.

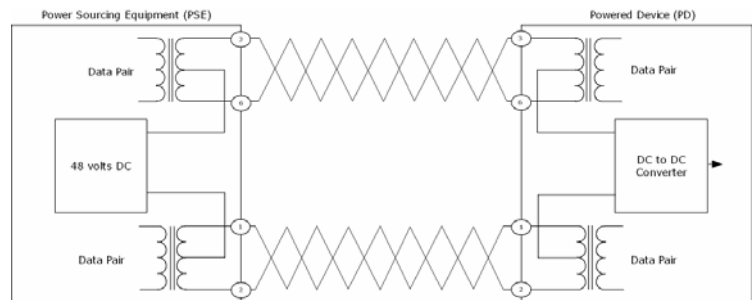

Figure 1. Power over Ethernet Alternative A

Alternative B carries power over spare wire pairs in the cable. The power sourcing equipment applies positive voltage to pins 4 and 5. Negative voltage is applied to pins 7 and 8.

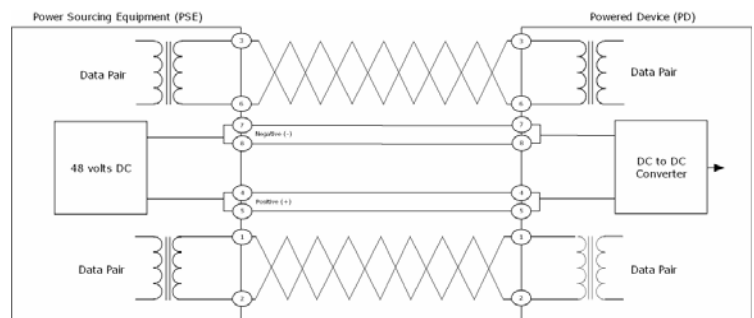

Figure 2. Power over Ethernet Alternative B

More on Powered Devices

PDs are designed to accept PoE in either format (Alternative A or B) so that they can receive power regardless of which Alternative is implemented in the PSE. When operating in Alternative A mode PDs automatically adjust for polarity of the power supply voltage. This ensures that the device will operate even if a crossover cable is being used. (This sometimes happens if a Media Dependant Interface (MDI), such as a PC network card, is connected to the PD, which also is wired as a MDI.)

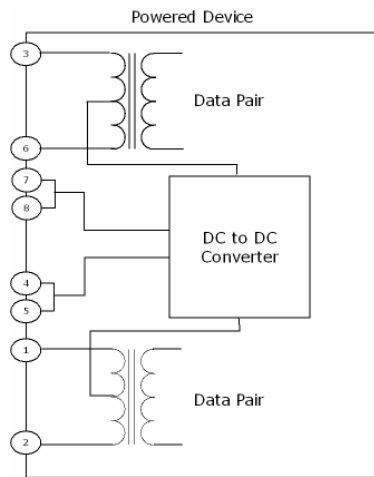

Figure 3. A Powered Device

PDs operate from 48 VDC (approximately) supplied by the PSE, which means they are classified as a *Safety Extra Low Voltage (SELV)* device. The maximum current supplied by the PSE is about 350 mA. With some loss in the CAT-5 cable, the PD is limited to about 12 watts of power. Maximum allowable cable resistance is 20 ohms.

More on Power Sourcing Equipment

The two types of PSE (endspan and midspan) are used in different situations. Endspan PSEs typically are used in new installations where a new switch or router is required. Midspan devices more often are added to an existing network to add PoE capabilities. Midspan devices are connected in-line, between the existing switch and the PD. They can be obtained as a single or multiple line units.

On initial power up Power Sourcing Equipment is designed to detect, and only supply power to the network device if it is identified as a PoE-enabled device. When first connected the PSE initiates a detection process that involves low probing voltages to sense the type of PD connected while avoiding damage to non-PoE network devices.

Some Power Sourcing Equipment may also detect the power class of the PD. PDs are assigned to one of the following five classes, depending on the amount of power they require.

Class	PD Power (W)	Note
0	0.44 to 12.95	Default
1	0.44 to 3.84	Optional
2	3.84 to 6.49	Optional
3	6.49 to 12.95	Optional
4	Future use	Future use

If a PD does not support classification it is assigned a default classification of 0, indicating the PSE should supply the maximum needed power. Classification of connected PDs allows the PSE to optimize its power distribution.

PSEs are able to detect several undesirable load conditions, including shorted communications cables, disconnected PDs and the connection of non-PoE devices. When a fault is detected the PSE will disconnect power from the communications line before damage can occur.

Power over Ethernet Glossary

PoE – Power Over Ethernet: A relatively new technology that allows PoE-enabled Ethernet networked devices to receive power (as well as data) over existing CAT-5 Ethernet cable without the need to make modifications to it.

PD - Powered Device: A Ethernet device that receives power over Ethernet. It could be a PoE-enabled IP phone, a wireless access point, a serial device server or any other IP device that requires power.

PSE – Power Sourcing Equipment: The network PoE element that inserts power onto an Ethernet cable. It may be an *endspan* device, such as a PoE-enabled switch, or a *midspan* device located between the switch and the PD.

Midspan – A midspan device is a PSE that inserts power onto the Ethernet cable. It is situated between the LAN switch and the PD. Typically, midspan devices are added to existing networks to allow the use of PoE-enabled PDs.

Endspan – An endspan device is typically a switch that incorporates PoE capabilities. Endspan devices often are implemented when a new network is created, to avoid adding midspan devices as well as the switch.

IEEE 802.3af – An IEEE standard (ratified in June 2003) that defines the transmission of power over Ethernet infrastructure. Also called *Data Terminal Equipment (DTE) Power via Media Dependent Interface*.

Ethernet - Ethernet, an IEEE 802.3 standard, is the most commonly installed computer local area network technology. Ethernet uses a bus or star topology and relies on the form of access known as Carrier Sense Multiple Access with Collision Detection (CSMA/DC) to regulate communication line traffic.

CAT-5 – Category 5 cable is the standard type of UTP cable used for horizontal Ethernet wiring. CAT-5 cable contains eight conductors, of which four are used for data communication in 10BaseT and 100BaseTX Ethernet.

Access Point – A wireless LAN device that interfaces with a wired Ethernet LAN.

RJ-45 – Registered Jack Standard 45. The RJ-45 is a single-line jack for digital transmission over ordinary phone wire, either untwisted or twisted. It is the interface of Ethernet standards 10BaseT and 100BaseT. The connector has eight connector points and can accommodate up to eight wires.

UTP – Unshielded Twisted Pair. The cable used for most telephone wire, and is also used for some computer-to-computer communications. It contains pairs of unshielded wires twisted together and is an inexpensive and relatively low-noise way to transmit signals. CAT-5 cable is UTP.

STP – Shielded Twisted Pair: A cable type sometimes used in networking. Each pair has a metal sheath around it for protection against interference.

SELV – Safety Extra Low Voltage: A circuit which is so designed and protected that, under normal and single fault conditions, its voltages do not exceed a safe value (60 VDC).

MDI / MDI-X – Media Dependent Interface: In Ethernet cable wiring, the concept of transmit and receive are from the perspective of the end device (PC network card, IP phone, device server, wireless access point, etc). The end device is wired as an MDI—data is transmitted on pins 1 and 2, received on pin 3 and 6. The hub, switch or router used on the network is wired as an MDI-X in which the perspective is reversed, and pins 1 and 2 are the receive pins, pins 3 and 6 are the transmit pins. To connect two end devices (e.g. two computers with network interfaces) a crossover cable is required.

DTE – Data Terminal Equipment: A communications element that is a source of data, as opposed to Data Communications Equipment (DCE), which accepts data from the DTE and transfers it to another DCE. PCs are a typically DTE.

Galvanic Isolation – Electrically isolating two parts of a circuit so that no current can flow between them. This is accomplished using a transformer or optocoupler and is often done to maintain safety for the equipment and personnel using it.

DC/DC converter – An electronic device that converts DC power at one voltage to DC power at another voltage (may be higher or lower voltage). The input and output sides of the converter typically are galvanically isolated from each other.

Switch – A networking device that connects multiple computers on a LAN so they can communicate with one another, the rest of the network and the internet. Unlike a hub, users connected to a switch do not share the available bandwidth. Each switch port runs at the full bandwidth of the switch port. A switch keeps track of MAC addresses attached to each of its ports and switches data to the intended recipient.

Hub – A connection device for networks that allows multiple segments or computers to connect and share packets of information. Hubs merely reproduce and re-send data pulses and do not switch the data based on its address or content.

LAN – Local Area Network. A communications network connecting a group of computer, printers, and other devices located within a relatively limited area (such as a home, office or small building). A LAN allows any connected device to interact with any other on the network. A LAN in turn often connects to other LANs, and to the Internet or other WAN.

Phantom Feeding – A technique for supplying power to a circuit in which the DC voltage is applied equally to two signal conductors, usually by simplexing the DC power using the center tap of signal coupling transformers. The DC power is removed from the signal at the receiving using another set of coupling transformers.

###